

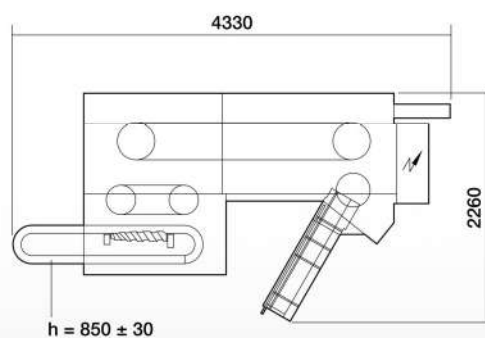

AVC

kontinuierliche, vertikale Kartoniermaschine

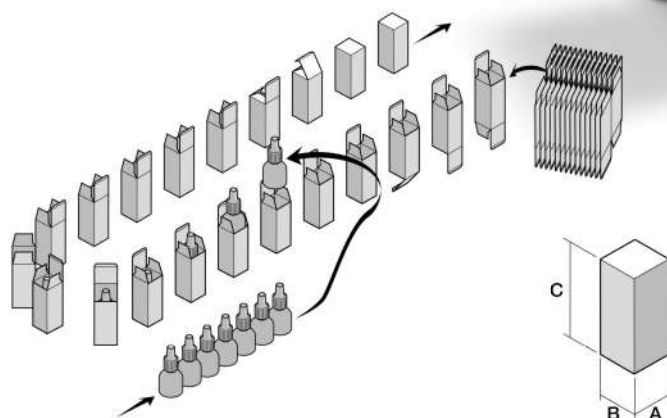
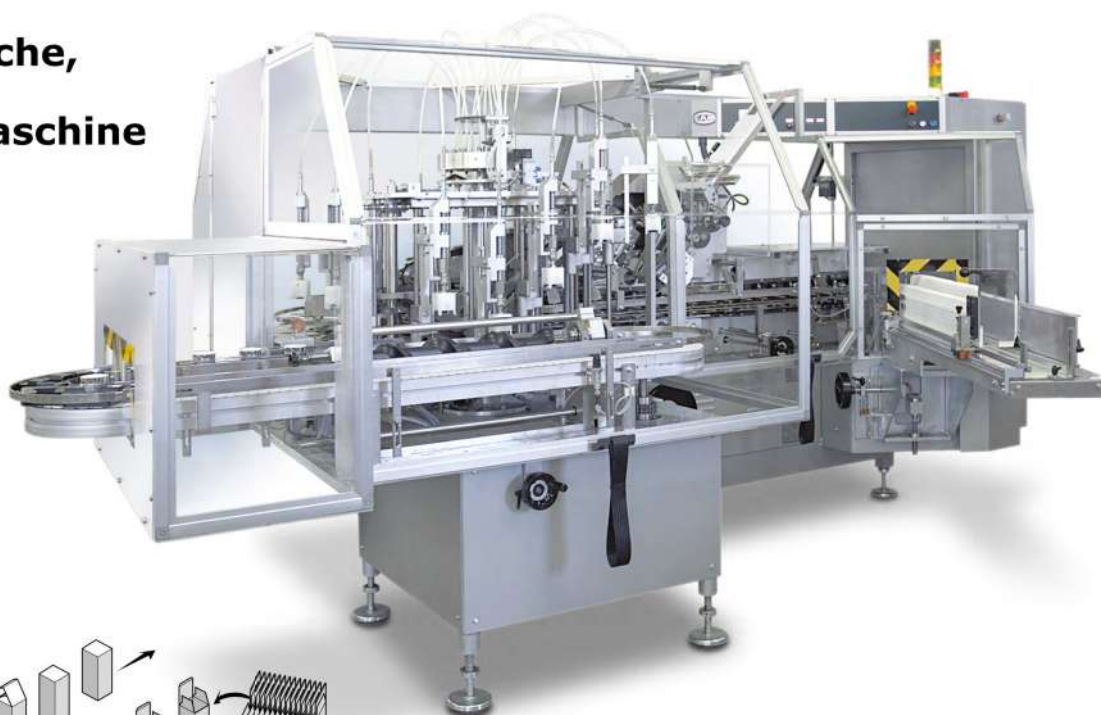

Technische Daten		AVC/1	AVC/2
Mech. Geschwindigkeit	TAKTE/1'	max. 300	max. 200
Motoren	kW	2.75	2.75
Elektrische Leistung	kW	3.8 (Leimverschl. + 3.9)	3.8 (Leimverschl. + 3.9)
Druckluftverbrauch	NI/1'	16.9	16.9
Druckluft	bar	5-6	5-6
Brutto Gewicht	kg	~2400	~2400
Netto Gewicht	kg	~2000	~2000

Formatbereich	AVC/1	min.	max.	AVC/2	min.	max.
A		30	65		35	115
B		30	80		30	100
C		55	250		55	250
A + B		-	145		-	190

